

- 1
- 2
- 3
- 4
- 5
- 6
- 7
- 8
- 9
- 10
- 11
- 12
- 13
- 14
- 15
- RH

MATERIAL

Glass-fibre reinforced polyamide based (PA) technopolymer, black colour, matte finish.

STANDARD EXECUTIONS

AISI 304 stainless steel screws and nuts.

- **MPG-C-S**: housings for round guides, without pin.
- **MPG-C-S-P**: housings for round guides with AISI 304 stainless steel pin.
- **MPG-T-S**: housings for standard trapezoidal guides, without pin.
- **MPG-T-S-P**: housings for standard trapezoidal guides with AISI 304 stainless steel pin.
- **MPG-R-S**: housings for rectangular guides, without pin.
- **MPG-R-S-P**: housings for rectangular guides with AISI 304 stainless steel pin.
- **MPG-P**: AISI 304 stainless steel guide assembly pin.

FEATURES AND APPLICATIONS

MPG-T-S and MPG-T-S-P executions can be used with the side guides having an AISI 304 stainless steel bracket of thickness 1.5 or 2 mm.

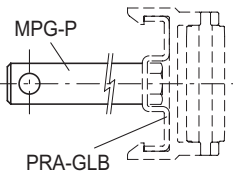

Conversion Table 1 mm = 0.039 inch			
d1		d	
mm	inch	mm	inch
8	0.31	12	0.47
10	0.39	14	0.55
12	0.47	16	0.63
14	0.55		

MPG-C-S

MPG-C-S-P

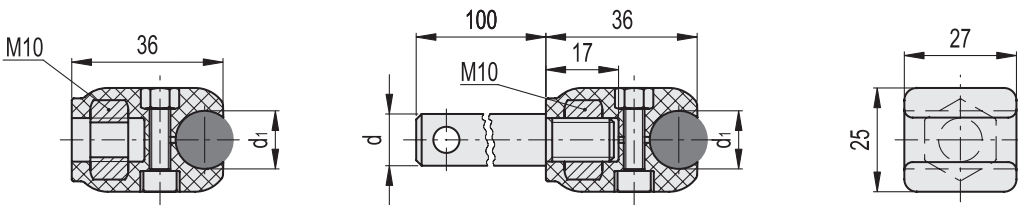

INOX STAINLESS STEEL METRIC

MPG-C-S
MPG-C-S-P

Code	Description	d	d1	△
419810	MPG-C-S-8	-	8	37
419811	MPG-C-S-10	-	10	36
419812	MPG-C-S-12	-	12	35
419813	MPG-C-S-14	-	14	34
419798	MPG-C-S-P12-8	12	8	128
419799	MPG-C-S-P12-10	12	10	127
419800	MPG-C-S-P12-12	12	12	126
419801	MPG-C-S-P12-14	12	14	125
419802	MPG-C-S-P14-8	14	8	162
419803	MPG-C-S-P14-10	14	10	161
419804	MPG-C-S-P14-12	14	12	160
419805	MPG-C-S-P14-14	14	14	159
419806	MPG-C-S-P16-8	16	8	198
419807	MPG-C-S-P16-10	16	10	197
419808	MPG-C-S-P16-12	16	12	196
419809	MPG-C-S-P16-14	16	14	195

Levelling elements and supports

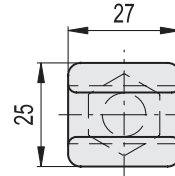
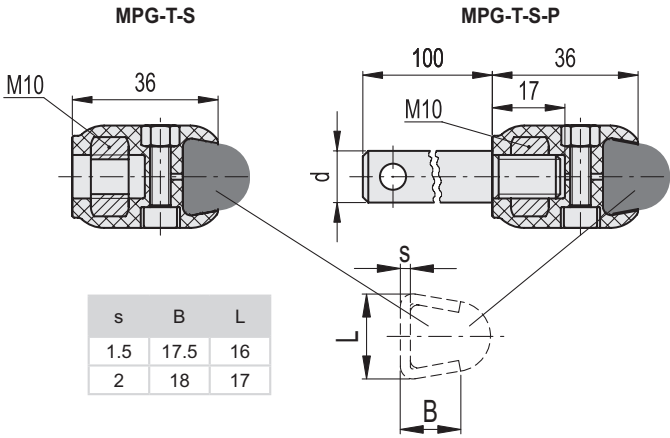

Conversion Table			
1 mm = 0.039 inch			
d1		d	
mm	inch	mm	inch
8	0.31	12	0.47
10	0.39	14	0.55
12	0.47	16	0.63
14	0.55		

INOX STAINLESS STEEL

METRIC

MPG-T-S
MPG-T-S-P

Code	Description	d	⚖️
419817	MPG-T-S	-	34
419814	MPG-T-S-P12	12	125
419815	MPG-T-S-P14	14	158
419816	MPG-T-S-P16	16	195

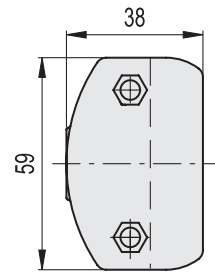
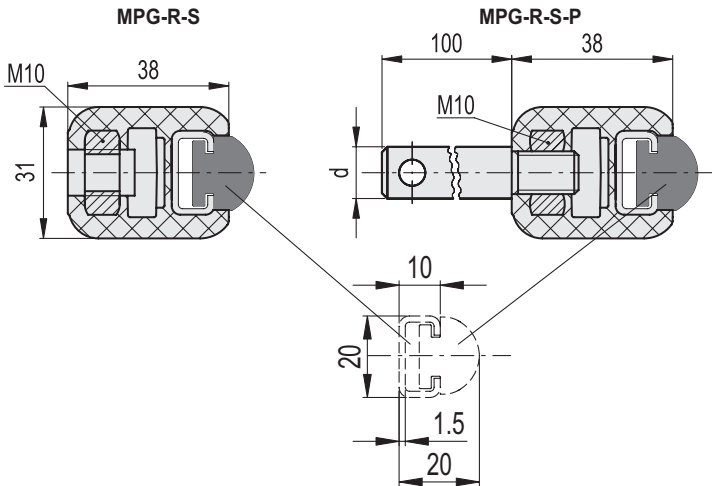

INOX STAINLESS STEEL

METRIC

MPG-R-S
MPG-R-S-P

Code	Description	d	⚖️
419827	MPG-R-S	-	47
419824	MPG-R-S-P12	12	201
419825	MPG-R-S-P14	14	235
419826	MPG-R-S-P16	16	262

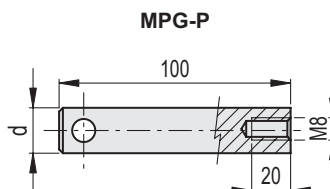

INOX STAINLESS STEEL

METRIC

MPG-P

Code	Description	d	⚖️
419690	MPG-P12-M8	12	90
419691	MPG-P14-M8	14	110
419692	MPG-P16-M8	16	130



Leveling elements and supports